

OB7 Seven Axis Work Envelope Advantage

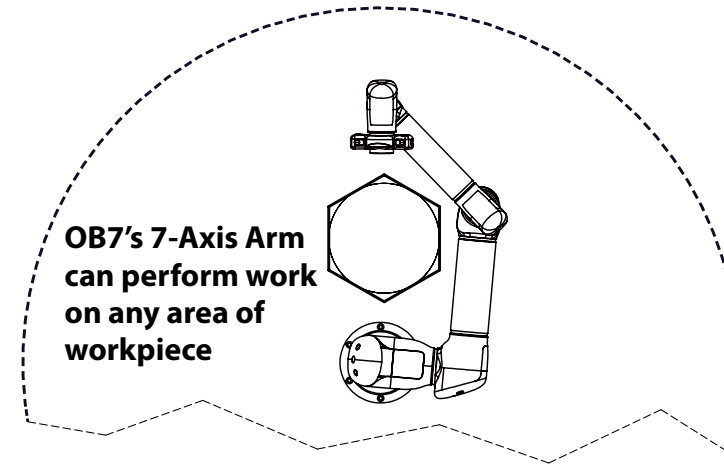
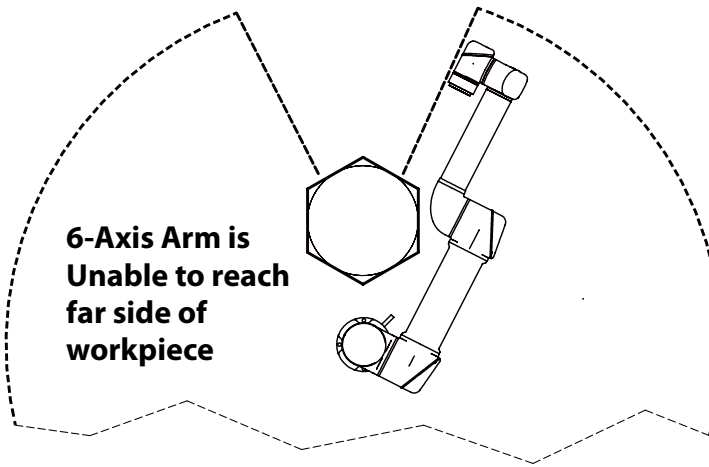

What is OB7's 7th Axis all about?

A 7th Axis, sometimes called "7 Degrees of Freedom", just means ultimate flexibility. Like a human arm, 7 joints give OB7 the flexibility and dexterity to reach around objects or obstacles in the work area, which is impossible with only 6 axes.

Beyond the capability of a human arm, each of OB7's joints can rotate 360 degrees in

both directions. 7 axes, each with +/- 360 degrees of rotation, allows OB7 to work in more confined work spaces and reach areas that a 6 axis robot can't reach.

The increased flexibility of 7 axes enables more ergonomic work-efficient orientations to streamline the job automation.

OB7 ROBOT Specifications:

- Payload:** 11 lbs / 5 kg
- Reach:** 1 meter / 39 in (gripper dependent)
- Weight (arm-only):** 58 lbs / 26 kg
- Repeatability:** +/- 0.1 mm, +/- .004
- Flexibility:** 7 joints
- Robot Mounting Flange Diameter:** 220 mm
- Gripper Mounting Flange:** ISO 9409-1-50-4-M6
- Working Temperature:** 32-100F 0-37C
- Power Source:** 100-240 VAC 50-60hz
- Uninterruptible Power:** 15 minutes (robot stopped) for moving robot to new location
- Power Consumption:** 90W-650W dependent on speed and payload
- Safety:** Power and force limited, compliant. (when running under ISO 10218-1 arm power is limited to 85W)
- Linear Speed:** 3 m/sec max (dependent on position)
- Movement and Speed:** +/- 360° approx 180°/sec All Axes
- Camera:** 5Mp color, USB
- IP Classification:** IP 62
- Noise Level:** Quiet (Speed/payload dependent)
- Mounting Orientation:** Any angle
- Cable length:** 6 meters (when not on stand)

Optional Accessory Specifications:

- PRI Parallel Electric Gripper**
- Gripping Force:** 0-140 N
- Full travel close/Open Time:** 1 sec.
- Force control:** Set by robot
- Open/Close positions:** Set by robot.



YUSHIN

35 Kenney Drive | Cranston, RI 02920
YushinAmerica.com | SalesInfo@yushin.com | 401.463.1800

Address

Productive Robotics Inc.
1033 Cindy Lane
Carpinteria, CA 92013 USA

Phone & Fax

Phone: 805-244-9300
Sales: 805-244-9300 ext. 7001
Support: 805-244-9300 ext. 7117

Online

Email 1: info@productiverobotics.com
Email 2: sales@productiverobotics.com
Website: www.productiverobotics.com

OB7 Collaborative Robot

Smart Simple Safe & Flexible

YUSHIN productive robotics™

Next Generation Collaborative Robots

For Automating All Areas of Manufacturing



Next Generation Collaborative Robots



Collaborative Automation is Now within your Grasp

INTRODUCING OB7 THE SMART 7 AXIS COLLABORATIVE ROBOT

OB7 was designed to deliver unmatched automation productivity, accuracy, and Safety. And, you can do it all simply without complicated software programming and coding.



A Simple "No Programming" Interface

OB7 LEARNS WITH NO PROGRAMMING

If you can do the job, you can show OB7 how to do the job. Learning without programming means that anyone can teach OB7 to do hundreds of complex automation jobs simply and quickly.

NEXT GENERATION COLLABORATIVE & SAFE

OB7 is the next generation of collaborative robots, with new functionality and systems designed to reduce costs and safely open new productivity horizons. OB7 is fully compliant with ISO 10218-1, work safety guidelines and requirements. When equipped with safety sensors, OB7 can safely work at high speeds when people aren't present then slow to safe speeds when people are nearby.



AUTOMATE ALL AREAS OF MANUFACTURING

- Loading, Unloading and Part Removal
- Machine Tending and Batch Production
- Gluing, Painting and Welding
- Polishing, Cutting, Deburring and Grinding
- Packaging and Palletizing
- QC Measuring, Testing, and Inspection



Machine Shop Loading & Unloading



Quality Control & Inspection

SEAMLESS INTEGRATION

INTO EXISTING PRODUCTION & WORK CELLS

OB7 can roll into an existing production line and start to work quickly. With an 11 lb. (5 kg) payload capacity, a 1 meter reach and .1 mm repeatable accuracy, OB7 is ideal for hundreds of precision production automation jobs.

10 Day Cash flow Payback

OB7 productivity goes straight to your cash flow. With OB7 financing, the cash flow payback time is typically 10 days. Hourly lease cost is \$3.50 per hour (single shift, 5 days/week) or less (\$1.25/hr for 2 shifts-7 days/week). OB7 is generating cash in only 10 days.



Pick & Place



Assembly & Gluing

VIRTUALLY NO MACHINE DOWN TIME

No down time waiting to re-engineer your production line and no waiting for software programming. OB7 is the cost slashing solution to maximize machine run time, while lowering delivery times and manufacturing costs. OB7 is designed to quickly move from one job to another.

ROLL-UP & RUN BATCH PRODUCTION

Batch Production is as simple as rolling OB7 up to the production line, reading QR code positioning tags, and selecting the job. In minutes you are in production with predictable repeatability.

OB7 • Grippers • Accessories

OB7 Collaborative Robot

The OB7 Collaborative Robot is sold as a fully functional automation system.

The basic package includes the OB7 7 Axis robot arm with on-arm controls & camera, proprietary OB7 computer, OB7 Teach tablet, charging dock, control handle, computer system back-up power, 1 year hardware warranty, 1 year software upgrades, and online training videos.

OB7 is compatible with most application specific grippers and EOAT.

Basic Package



Important: OB7 is sold without a gripper or other end of arm tooling. Job specific gripper options are available and sold separately. The Productive Robotics electric two finger gripper listed below is a cost effective gripper that is suitable for hundreds of job applications.

OB7 Rolling Stand (optional)

The industrial quality OB7 Rolling Stand is a stable and easily movable robot stand. Mounted on the OB7 Rolling Stand, OB7 can be quickly moved between work cells. An integrated battery back-up power supply keeps OB7 powered up and running when moving between work sites.



Base Dimensions: 780 mm x 597 mm, 30.7" x 23.5"
Robot Base Mounting: 882 mm (32.75") height
Weight: 73.5 kg (162 lbs)
Casters: 4
Leveling Feet: 4

OB7 Assembly Table (optional)

The optional Assembly/Work Table, is 6061-T6 anodized aluminum, and mounts securely to the OB7 Rolling Stand to provide a universal work surface. An integrated grid of alternating threaded work fixture hold-down and pin registration holes provides a fast and convenient work fixture installation and changes.

Note: OB7 Rolling Stand sold is separately.



Dimension: 27.6" x 35.5" (702 mm x 902 mm)
Table Weight: 51 lbs (23 kg)
Registration Holes: 1/4" on 2" centers (6 mm on 50 mm centers)
Fixture Hold Down Holes: 1/4" on 2" centers (M6 on 50 mm centers)

Electrical Gripper (optional)

The optional Productive Robotics Parallel Electric Gripper is a versatile and affordable solution for hundreds of production applications. Gripping force, speed & opening position are set automatically or manually by OB7.

Gripping force: 0-140 N.
Full travel close/open time: 1 sec.
Force control: Set by robot
Open/Close positions: Set by robot



General Equipment Interface (optional)

The OB7 General Equipment Interface (GEI) is a cost effective solution for interfacing OB7 to most production machinery. The interface has 8 electrically isolated digital inputs, 8 electrically digital outputs, and 4 analog inputs. The OB7 GEI connects to OB7 with a single cable which can be unplugged when moving OB7 between jobs.

