

YUSHIN

MKA series

Large Powerful Take-out Robot

Solutions by Industry



Automotive



Appliance



Industrial Construction



Clamping force of Compatible
Molding Machines

1500 tons or Larger

YUSHIN MKA

**TURN-KEY SOLUTIONS FOR
YOUR DOWNSTREAM
AUTOMATION**

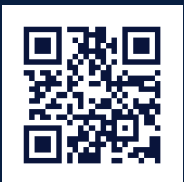

YushinAmerica.com



SPEED

Completely redesigned arm and kick units dramatically reduce take-out time compared to previous models.

TECHNOLOGY

Energy & Air conservation. More energy-efficient servo motors & ECO Vacuum. Monitor & measure in real-time

RELIABILITY

Increased rigidity and vibration damping applied to the arm delivers steady take-out and release action

SUPPORT

Reliable 24/7 customer support for parts & life of your equipment.
For Technical Support: 401.463.1800, dial Opt. 2

• ROBOTS • END-OF-ARM TOOLS • CONVEYORS • SAFETY GUARDING •

MKA-2000S Robot is Exclusively Sold & Distributed in North America & Mexico

Powerful Selection of Standard Features

FEATURES

- Powerfully automate extraction of large, heavy molded parts such as automobile parts, housing appliances, and parts for industrial equipment.
- 3-axis Traverse robot with Movable Kick Beam and 2-stage Telescopic Vertical arm. Servo Wrist Units optional.
- Vertical arm extends to 3000mm on presses 1500tf or larger.

BENEFITS

Shorter overall take-out time

MKA has shorter accurate take-out times by 17% compared to previous larger models. Telescopic Vertical arm allows End-of-Arm-Tool to move at shorter stroke lengths.

Smooth, Stable Take-out

Part take-out, handling, and release motions are smooth on the MKA. Its superior vibration damping during movement helps ensure stable, and shorter cycle times by 10%, compared to previous larger models.

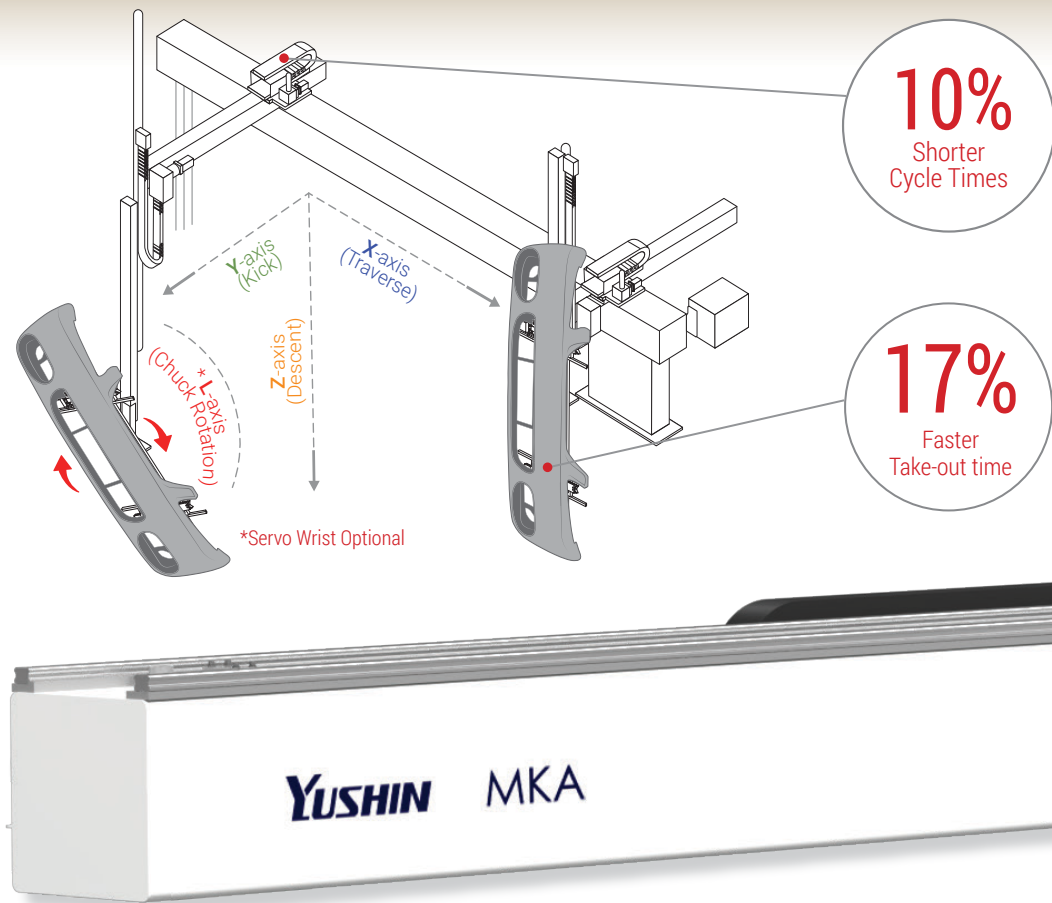

MKA-2000S

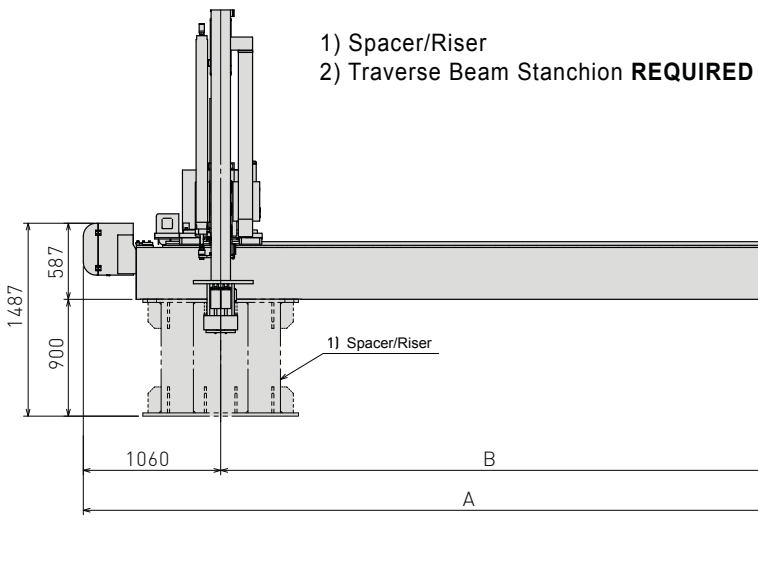
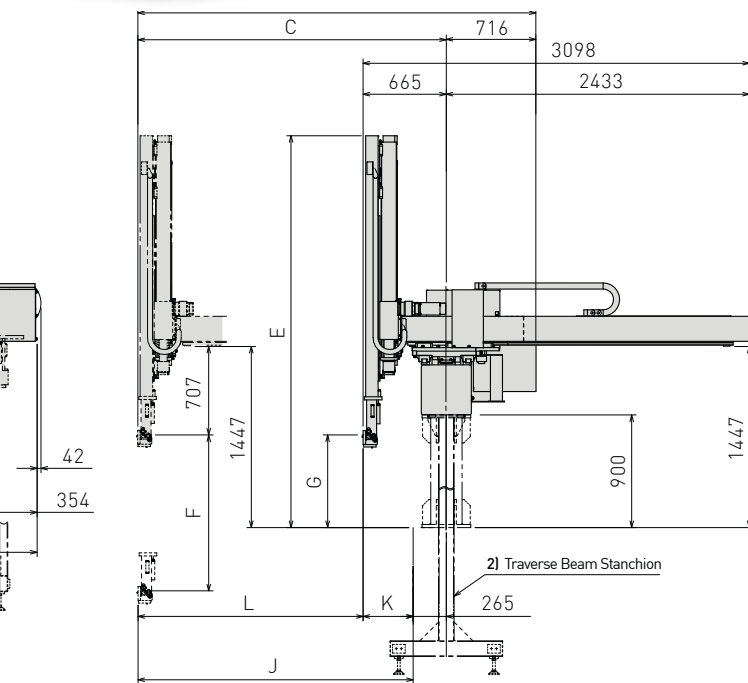

[] : Modified traverse stroke
[] : Modified vertical stroke

Model	A	B	C	D	E	F	G	J	K	L
MKA-2000S	(5414) 5914 (6414)	(4000) 4500 (5000)	2465	3181	3132 [3380]	2500 [3000]	740	2200	400	1800

Standard Specifications

Power Source	Power Capacity	Power Consumption	Air Pressure	Maximum allowable Air pressure (factory)	Air Consumption *1 (NL / cycle) (0.49MPa)	Payload (kg) (includes EOAT)	Compatible IMM Tonnage (tf)	Weight (kg)	Controller	Wrist Flip Angle *2
3 phase AC200V/220V/230V 50/60Hz	3.0 kVA AC200V x 11.8A Max	463W	0.49 MPa	0.45 ~ 0.50 MPa	78 (ECO Vac OFF) 60 (ECO Vac ON)	50 « 40 » « 30 »	1500 or larger	1430	E-touch compact	Flip by air

< > = modified traverse stroke; [] = modified arm stroke; « » = high speed variants

*1: Air consumption for 1 air circuit with 1-position release

*2: Optional - Add 2 servo powered axes of motion to the arm wrist, available in "wrist vertical rotation + flip".

E-touch Compact



STANDARD EQUIPPED

Enhanced Convenience

Loaded with Convenient New Functions like Predictive Maintenance.

The E-touch Compact controller features a highly visible 7.5 full-color touchscreen, a comfortable one-handed grip, and powerful yet user-friendly robot controls.

NEW Predictive Maintenance

Continuously monitors robot during operation and alerts operator with a message if potential trouble symptoms are detected. This function elevates maintenance from preventative to predictive.



NEW Flowchart Display

If an operation goes away (such as when run conditions are not met at the start of auto operation) rather than just read an error message, the operator can open a flowchart screen to check conditions quickly and speed up troubleshooting.

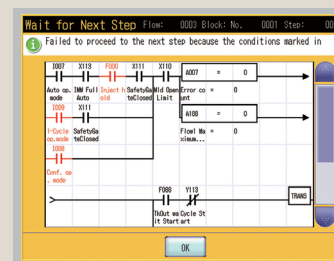

NEW Enhanced Manual Operator Screen

1) Manual controls for all axes are grouped on one screen for easier operation.
2) For easier reference, operators may now access the robot control guide even while using the manual operation screen.

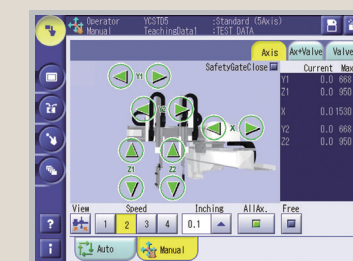

Lead Through Teaching

Allows users to easily make various kinds of changes to robot programs right on the shop floor, helping to save time and programming costs.

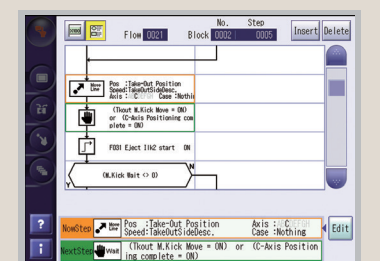

OPTIONS

* Installing some options may affect standard specifications such as stroke length and maximum payload. Please consult your local Yushin Sales Representative.

Option Name	Description
Servo Wrist	Add 2 servo-powered axes of motion to the arm wrist, enabling precision control and motion comparable to an articulated 6-axis robot. Available in: "wrist vertical rotation + flip". Servo wrist dependent on payload capacity.
Additional Vacuum Circuits Add Release Points	Up to 3 optional vacuum circuits may be added to the one standard-equipped circuit to expand release positions up to 4.
Additional Product Chuck Circuits	1 or 3 optional chuck circuits may be added to the single standard-equipped circuit for a total of 2 or 4 product gripper circuits.
Additional Sprue Chuck Circuits	Allows the timing of the sprue release to be set via mode selection. 1 or more additional circuits may be added to the single, standard-equipped circuit.
Pitch Revise Circuit	Allows operator to specify pitch of parts gripped by the end-of-arm tool.
Sprue Cut Circuit	Allows nippers on-board the end-of-arm tool to cut sprues. May not be equipped together with EOAT Gate Circuit option.
EOAT Gate Cut Circuit	Enables cutter within end-of-arm tool to approach the gate of a part and cut it. May not be equipped together with Cut Circuit option.
Chuck Soft Grip Circuit	A pressure reducing valve is added to adjust chuck grip and prevent deformation of molded products.
EOAT One-Touch Quick-Release Fitting	Allows for fast manual attachment/detachment of end-of-arm tool.
Signal Light	Robot status indicator lights. Available in single red, single yellow (red + yellow) models.
8-Pin Stocker Unit Connector	Metal connector which allows robot to interface with Yushin-made stocker unit.
Pause for Mold Open	Used for manual ejection.
Centralized Manual Lubrication System	Delivers lubricant from manual pump to necessary areas. Standard Function of the MKA series.
Centralized Automatic Lubrication System	Delivers lubricant from electric pump to necessary areas.
Low Air Pressure Detection	Robot error-stops if air supply's pressure drops below a set value.
IMM Data Link	Robot communicates mold numbers and other information with the molding machine to automatically synchronize set-up data.
Bilingual Display	2 user-selectable display languages are installed in controller (English and Japanese language are standard-equipped; Spanish language is installed as an option).
Flipped Gate Cut Mode	Mode where robot wrist flips prior to gate-cut sequence.
4-Position Gate Cut	User can set up to 4 gate-cut sequences, each with a different wait position prior to advancing to cut (up to 3 wait positions may be set).
Kick Free	Allows free movement of kick axis with mold ejector stroke.



YUSHIN UNIVERSITY

online resource and training center

GET YUSHIN CERTIFIED:

- Robot Operation •
- Mode Selects •
- Lead Through Teaching •

For more information about Yushin University, contact us at (401) 463-1800 or at info@yushinuniversity.com

◇ PARTS & SERVICE. Yushin-Approved Robot Tooling and Accessories. Email: webparts@yushin.com

Need a replacement manual or have a machine down? Our team of dedicated technical service engineers is available to help with immediate issues over the phone or via email, supported by on-site service visits when necessary. Telephone support for Yushin equipment is available 24 hours a day, 7 days a week.

Considering an order of spares or need an emergency replacement part right away? With decades of experience and access to million-dollar-plus parts inventory, our knowledgeable parts department are always prepared with a comprehensive in-house parts inventory & quick turnaround times.



YAI Facility has over 70,000 Sq. ft. of Robot Manufacturing, Parts and Inventory.

YUSHIN AMERICA, Inc.

35 Kenney Drive
Cranston, RI 02920 USA



YAI Technical Support

1.888.707.6268 | 401.463.8398

webservice@yushin.com



www.YushinAmerica.com

Email: SalesInfo@yushin.com

Tel: 401.463.1800

MKA-2000S info



YushinAmerica.com

